

Relay Module 788 Series

1

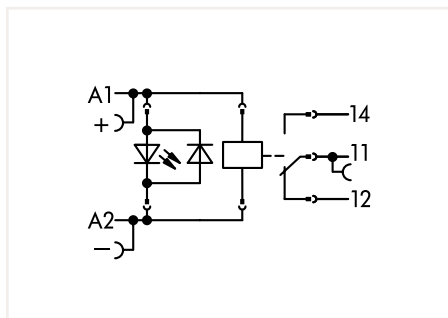

Relay Module; 1 changeover contact; Limiting continuous current: 16 A; for lamp loads; Status indicator: red; 15 mm wide

U_N	I_N	Item No.	Pack. Unit
12 VDC	35 mA	788-353	20
24 VDC	19 mA	788-354	20

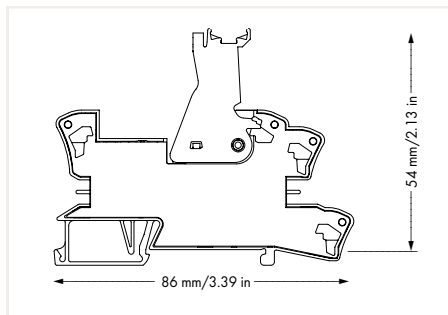

Note:

- Reinforced insulation between coil and contacts
- A separator plate (e.g., 209-191) must be used for voltages greater than 250 V between adjacent relay modules and for compliance with the reinforced insulation requirements.
- To protect the relay coils and contacts, inductive loads must be dampened with an effective protection circuit.

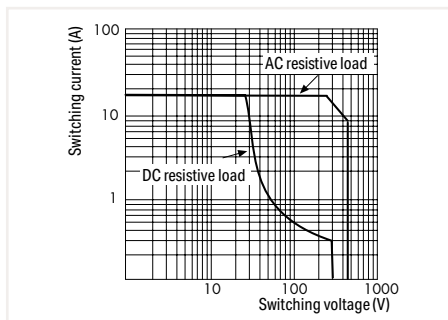

Load Limit Curve

Control Circuit

Input voltage range	-15 ... +20 %
---------------------	---------------

Load Circuit

Number of changeover/switchover contacts	1
Contact material	AgSnO ₂
Limiting continuous current	16 A
Inrush current (resistive) max.	120 A (AC) / 50 ms
Switching voltage (max.)	250 VAC
Switching power (resistive) max.	4000 VA (AC); DC see load limit curve
Recommended minimum load	5 V / 100 mA
Pull-in time (typ.)	15 ms
Drop-out time (typ.)	5 ms
Electrical life (NO; resistive load; 23 °C)	100 x 10 ³ switching operations
Mechanical life	10 x 10 ⁶ switching operations

Signaling

Status indicator	Red LED
------------------	---------

Safety and Protection

Rated voltage	250 V
Rated surge voltage	4 kV
Pollution degree	3
Dielectric strength, control/load circuit (AC, 1 min)	5 kV _{rms}
Dielectric strength, open contact (AC, 1 min)	1 kV _{rms}
Protection type	IP20

Connection Data

Connection technology	Push-in CAGE CLAMP®
Solid conductor	0.34 ... 2.5 mm ² / 22 ... 14 AWG
Fine-stranded conductor	0.34 ... 2.5 mm ² / 22 ... 14 AWG
Strip length	9 ... 10 mm / 0.35 ... 0.39 inch

Physical Data

Width	15 mm / 0.591 inch
Height from upper-edge of DIN-rail	54 mm / 2.126 inch
Depth	86 mm / 3.386 inch

Mechanical Data

Mounting type	DIN-35 rail
---------------	-------------

Material Data

Weight	44.4 g
--------	--------

Environmental Requirements

Surrounding air temperature (operation at U_N)	-40 ... +70 °C
Surrounding air temperature (storage)	-40 ... +70 °C
Processing temperature	-25 ... +50 °C

Standards and Specifications

Standards/specifications	EN 61010-2-201; EN 61810-1; EN 61373; UL 508 (max. 10 A)
--------------------------	--

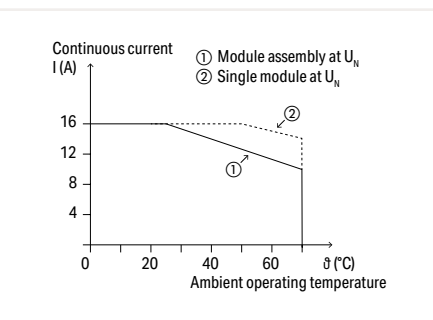

Current-Carrying Capacity Curve